



PROCESSES



TIG (GTAW)
Welding



Stick (SMAW)
Welding

5/3/1
WARRANTY



The TIGMATE is a complete AC/DC, TIG and Stick welding package. There are no hidden costs or extras to buy. All you need is a bottle of shielding gas and some Stick electrodes and you're ready to start welding. It's ideal for farmers, ranchers and hobbyists.

In the TIG mode, the TIGMATE offers superior performance: 18 gauge to 3/16 in (1.2 to 4.8 mm) steel and stainless steel; 14 gauge to 3/16 in (1.8 to 4.8 mm) aluminum (see table on page 3).

For thicker metals, take advantage of the Stick mode using 3/32 and 1/8 in (2.4 and 3.2 mm) electrodes.

FEATURES

BENEFITS

Upgraded circuitry	Allows for finer TIG output adjustment with the remote foot or fingertip control. If you need more output while using the remote control, simply increase the setting of the front panel amperage control.
AC output	For superior aluminum welding
DC output	For mild and stainless steel
Four-position polarity and range selector switch	Offers two AC current ranges, DC electrode (-) for TIG, and DC electrode (+) for Stick
Special arc-starting circuitry	Eliminates high-frequency starts.
Built-in arc assist starter	For DC TIG
Built-in arc assist stabilizer	For AC TIG on aluminum
Process switch	Automatically sets machine for TIG or Stick
Unique "flow-through" shielding gas TIG torch connection	Allows removal of torch without tools
Preset automatic postflow timer	Protects tungsten tip, workpiece and torch
Automatic high temperature shutdown	Helps prevent costly power source repairs

SPECIFICATIONS (SUBJECT TO CHANGE WITHOUT NOTICE.)

LIGHT INDUSTRIAL



Process	Rated Output at 20% Duty Cycle	Welding Amperage Range			Max. Open-Circuit Voltage	Input Amps at Rated Output	Dimensions	Net Weight
		AC High	AC Low	DC				
TIG	150 A at 15 VDC 150 A at 15 VAC	50-165	20-50	30-160	78	230 V - 52 A 380 V - 39 A 200 V - 60 A	H: 18 in (457 mm) W: 13 in (330 mm) D: 2.5-1/2 in (648 mm)	140 lb (64 kg)
Stick	130 A at 25 VDC 150 A at 25 VAC	35-165	20-50	25-130	78			

60 Hz models are certified by Canadian Standards Association to both Canadian and U.S. Standards.



Hobart Welders An Illinois Tool Works Company

U.S. Sales Phone 920-735-4576 FAX 800-637-2315
Canadian Sales Phone 888-489-9353 FAX 519-421-0480
International Sales Phone 920-735-4509 FAX 920-735-4125

Web Site www.HobartWelders.com



PACKAGE COMPONENTS



Just Supply Argon Gas,
Stick Electrodes,
Filler Rod, Gloves
& Helmet,
and You're Ready to Weld!



Fingertip Control*



Foot Control*

6 ft (1.8 m)
Power Cord
(Plug Supplied
with 230 Volt
Models Only)

Electrode Holder with
15 ft (4.6 m) Cable
and Quick-Connect

HOBART

150 Amp TIG Torch
with 12-1/2 ft (3.8 m) cord and
flow-through Quick-Connect



"How-To" Videotape



Gas Regulator
and Gas Hose

12 ft (3.7 m) Work
Cable and Clamp

Note: some assembly is required.

* **Select package with remote fingertip control or foot control.**
25 ft (7.6 m) TIG torch supplied with fingertip control models.

CONTROL PANEL

1. Range/Polarity Switch
2. Process Switch
3. Amperage Control
4. High Temperature Light
5. Remote Receptacle
6. Power Switch
7. International Flow-Through Receptacle

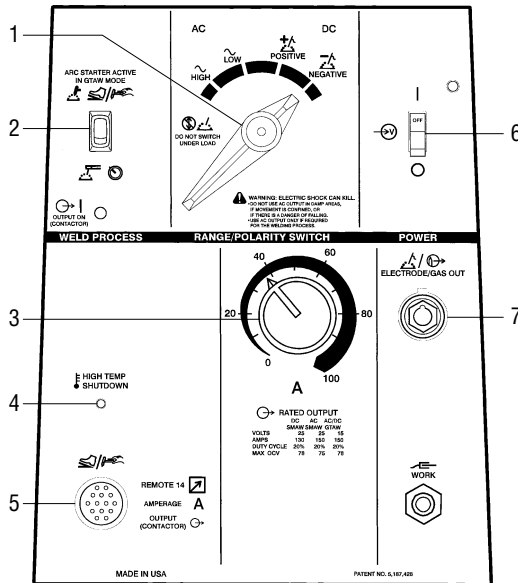



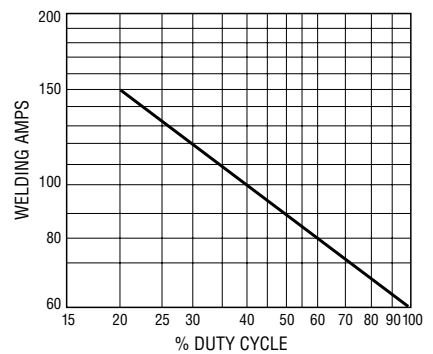

PERFORMANCE DATA

DUTY CYCLE CHART

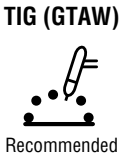

PROCESS AND MATERIAL THICKNESS GUIDE

Material and Weld Output	Material Thickness											
	22 ga 0.033 in 0.8 mm	20 ga 0.036 in 0.9 mm	18 ga 0.048 in 1.2 mm	16 ga 0.06 in 1.5 mm	14 ga 0.07 in 1.8 mm	12 ga 0.1 in 2.5 mm	11 ga 0.125 in 3.2 mm	10 ga 0.14 in 3.6 mm	6 ga 0.186 in 4.8 mm	2 ga 0.25 in 6.3 mm	— 0.25+ in 6.3+ mm	
Steel or Stainless Steel	 TIG (GTAW) Difficult						 TIG (GTAW) Recommended				Stick (SMAW)  With DCEP Output	
 DCEN Electrode Negative											Aluminum  AC	

ACCESSORIES



Universal Carrying Cart and Cylinder Rack #042 934

This cart adds convenience to the TIGMATE package. The power source mounts securely to the top, and a cylinder rack supports the argon cylinder. The bottom tray can hold electrode leads or welding hood, gloves, etc. Cylinder rack will accommodate 6–9 in (152–228 mm) diameter, and 24–56 in (610–1422 mm) high cylinders. Also supports five standard TIG filler metal tubes and one Stick welding rod tube. Net shipping weight is 69 lb (31 kg).



RCC-14 Remote Contactor and Current Control #151 086-01-1

A fingertip control can be used instead of the supplied remote foot control. Useful when welding where a foot control cannot be used.

This rotary-motion fingertip control fastens to TIG torch handle using two Velcro® strips. Includes 28 ft (8.5 m) cord and plug. Allows complete current and contactor control.



RHC-14 Hand Control #129 340-01-7

Miniature hand control for remote current and contactor control. Dimensions: 4 x 4 x 3-1/4 in (102 x 102 x 82 mm). Includes 20 ft (6 m) cord and 14-pin plug.



RCCS-14 Remote Contactor and Current Control #043 688

North/south rotary-motion fingertip control fastens to TIG torch using two Velcro® straps. Great for applications that require a finer amperage control. Includes 28 ft (8.5 m) control cord.



RFCS-14 Foot Control #043 554-01-1

Foot current and contactor control. Includes 20 ft (6 m) cord and 14-pin plug.

REPLACEMENT TORCHES NOTE: AVAILABLE THROUGH YOUR LOCAL WELDING DISTRIBUTOR.

Torch No.	Description	Torches equipped with “quick-connect” International-style connector. “Flow-through” shielding gas TIG torch connection allows complete removal of torch without using any tools.
17-12-R-ME1	12-1/2 ft (3.8 m) TIG Torch	
17-25-R-ME1	25 ft (7.6 m) TIG Torch	
DI-917F	Flow-through Connector	

ORDERING INFORMATION AND SYSTEM CHECKLIST

Power Source and Options	Stock No.	Description	Qty.	Price
TIGMATE	#500 424	230 V, 60 Hz, w/ Fingertip Control w/ 25 ft (7.6 m) TIG Torch		
	#500 425	230 V, 60 Hz, w/ Foot Control w/ 12-1/2 ft (3.8 m) TIG Torch		
	#500 426	380 V, 50 Hz, w/ Fingertip Control w/ 25 ft (7.6 m) TIG Torch		
	#500 427	200 V, 60 Hz, w/ Foot Control w/ 12-1/2 ft (3.8 m) TIG Torch		
Accessories				
Universal Carrying Cart and Cylinder Rack	#042 934			
RCC-14 Remote Contactor and Current Control	#151 086-01-1			
RCCS-14 Remote Contactor and Current Control	#043 688			
RHC-14 Hand Control	#129 340-01-7			
RFCS-14 Foot Control	#043 554-01-1			
Miscellaneous				
Argon Gas				
TIG Filler Rod				
Stick Electrodes				
Helmet/Gloves/Brush				
Wall Receptacle				
Date:				Total Quoted Price:

HOBART
W E L D E R S

Litho in USA

DISTRIBUTED BY:

--