

# Champion® Elite 225

## 225-Amp DC Stick Welder with 10,000-Watt Auxiliary Power



295419  
February 2024



500580

### Quick Specs

#### Welding Amp Range

25–225 A

#### Rated Output

225 A at 25 V, 100% duty cycle

#### Auxiliary Power

10,000 W peak, 9,500 W continuous



### All-in-one engine-driven welder with DC stick welding and auxiliary power.

The powerful yet lightweight design of the Hobart Champion Elite 225 offers 10,000-watt auxiliary power and DC welding capabilities, all in a compact package for ease of portability. The Champion Elite is built to optimize weld quality by providing quick and consistent arc starts.

Engine is warrantied separately by the engine manufacturer.

#### Applications

- Maintenance/repair
- Farm/ranch
- Fabrication
- Structural steel work
- Construction

Features	Benefits
<b>2-in-1 design</b>	225-amp welder with 10,000-watt peak auxiliary power allows the user to concurrently weld and use auxiliary power without disruption.
<b>Portable and compact</b>	Lightweight and portable design allows easy movement around the jobsite and better fuel efficiency when transporting. Compact design allows more space while operating equipment, as well as in the back of a vehicle.
<b>Vanguard engine</b>	Heavy-duty engine provides hours of reliable welding and auxiliary power to get any job done efficiently.
<b>Weld quality</b>	Enhanced weld technology allows for easy starts and consistent weld quality.
<b>Single knob amperage control</b>	With a single knob, simply pick the electrode size and begin welding.
<b>Multitude of power inputs</b>	Two 120-volt duplex receptacles, plus NEMA 6-50 and 14-50 receptacles provide power for anything from common jobsite tools to plasma cutters to power applications requiring four-prong receptacles.
<b>Auto idle</b>	Machine has greater fuel savings and reduced noise.
<b>Hobart 5/3/1 industrial warranty</b>	Five-year warranty on transformers, stabilizers and main rectifiers; three years on auxiliary power, PC boards and drive systems; and one year on guns (MIG, plasma and TIG torches).



#### Hobart Welding Products

An ITW Welding Company  
Sales: 800-626-9420  
Service: 800-332-3281

#### HobartWelders.com



## Specifications (Subject to change without notice.)



Welding Amp Range	Rated Output* (at 104°F/40°C)	Max. Open Circuit Voltage	Auxiliary Power	Dimensions	Net Weight
25–225 A	225 A at 25 V, 100% duty cycle	80 VDC	10,000 watts peak, 9,500 watts continuous, 120/240 V, 60 Hz	H: 26.5 in. (673 mm) W: 20.13 in. (511 mm) D: 37.06 in. (941 mm)	373 lb. (169 kg)

## Engine Specifications (Subject to change without notice.)

Engine Brand	Horsepower	Engine Type	Weld Speed	Idle Speed	Fuel Capacity	Oil Capacity/Change
Vanguard with 3-year mfg. warranty	23 hp at 3,600 rpm	Twin-cylinder, four-cycle, overhead valve, industrial, air-cooled, gasoline	3,600 rpm	2,400 rpm	11 gal. (41.6 L)	1.5 qt. (1.4 L) every 100 hours

\*Rated at sea level.



Certified by Canadian Standards Association to both the Canadian and U.S. Standards.

## Control Panel

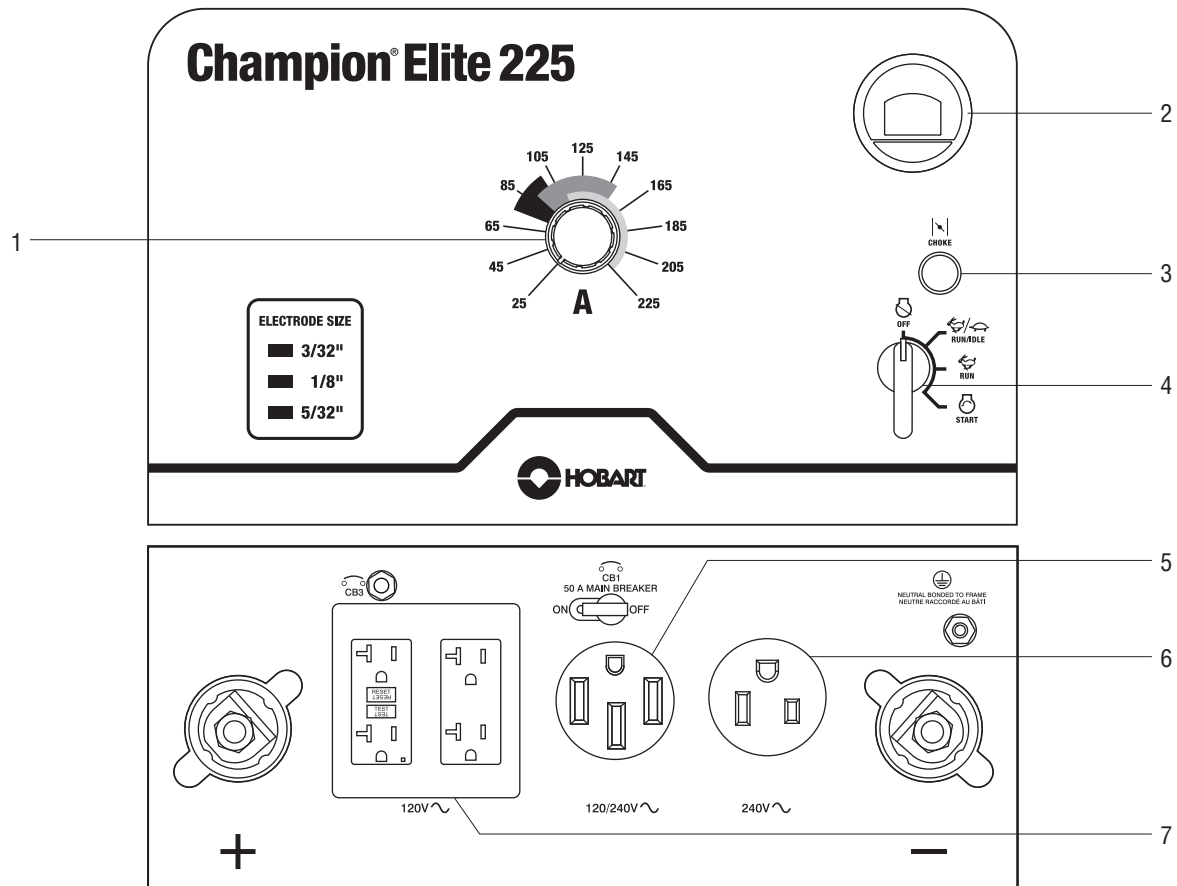

- 1. Amperage setting.** Single amperage knob allows user to control the amperage of machine from 25–225 A.
- 2. Digital engine hour meter/fuel gauge/maintenance interval tracking.** Digital meter displays engine hour meter, fuel gauge, and service reminders/notifications.
- 3. Engine choke control** allows adjustment of engine air/fuel mix for easy startup.
- 4. Engine control switch** allows for engine speed selection. In run/idle position engine runs at idle speed at no load, and weld/power speed under load.

Note: Protective covers for bottom portion of panel are not shown.

- 5. 120/240 V receptacle.** This versatile, 50-amp circuit-breaker-protected receptacle (NEMA 14-50R) can supply up to 10,000 watts of 240-volt power OR up to 10,000 watts of 120-volt power through two separate 120-volt circuits.
- 6. 240 V receptacle.** This handy, 50-amp circuit-breaker-protected receptacle (NEMA 6-50R), can be used to directly plug in your 240-volt Hobart equipment.
- 7. 120 V GFCI receptacles.** Protected by 20-amp circuit breaker.

## Performance Data

### Fuel Consumption Data

The Champion® Elite 225 offers a modern, fuel-efficient engine from Vanguard. With the OHV design, automatic idle and 11-gallon fuel tank, you can expect to put in long hours before having to stop and refuel. For example:

- Welding at 150 amps, 40 percent duty cycle, uses about 1.1 gallons of fuel every hour.
- Welding at 125 amps, 20 percent duty cycle, uses about 1.02 gallons of fuel every hour.
- While not welding, the engine drops to idle speed using about .44 gallons of fuel every hour.
- Under a continuous load of 4,000 watts of auxiliary power, the Champion Elite would run for about 11 hours and 45 minutes.

### Typical Power Requirements for Farm and Contractor Equipment

Equipment	Rating	Starting Watts	Running Watts
Portable Conveyor	1/2 hp	3,400	1,000
Farm-Duty Motors Std., (e.g. Conveyors, Feed Augers, Air Compressors)	1/3 hp	1,720	720
	1-1/2 hp	8,200	2,200
Hand Drill	1/2 in.	600	600
Circular Saw	8.25 in.	1,400	1,400
Table Saw	10 in.	6,300	1,800
Band Saw	14 in.	2,500	1,100
Flood Lights	HID	125	100
	Metal halide	313	250
	Mercury	1,000	—
	Vapor	1,250	1,000
Air Compressor	1-1/2 hp	8,200	2,200
Electric Chain Saw	2 hp, 14 in.	1,100	1,100
Submersible Pump	400 gph	600	200
Centrifugal Pump	900 gph	900	500
Wet and Dry Vac	1.7 hp	900	900
High Pressure Washer	1 hp	6,100	1,600

### Fuel Consumption

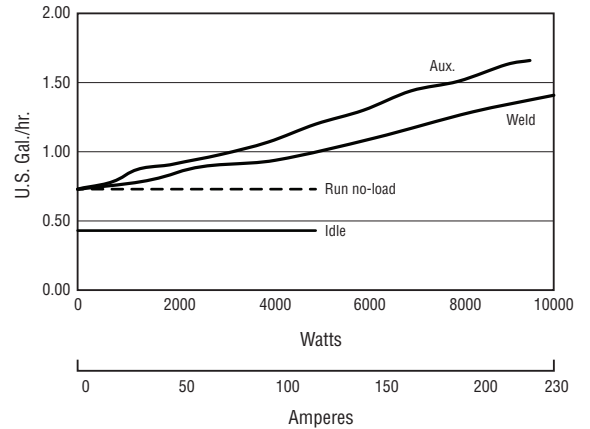

### Auxiliary Power Curve

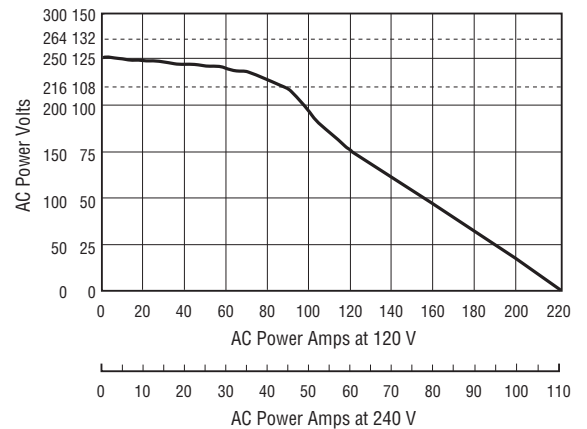

## Mounting Specifications

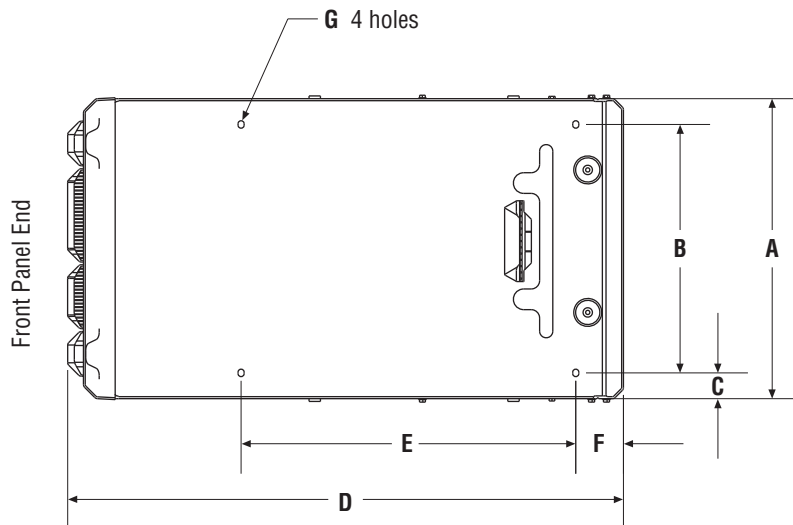

- A. 20 in. (508 mm)
- B. 16.562 in. (421 mm)
- C. 1.72 in. (44 mm)
- D. 37 in. (940 mm)
- E. 22.312 in. (567 mm)
- F. 3.18 in. (81 mm)
- G. .406 in. (10 mm) diameter

## Accessories



### Protective Cover 771023

Waterproof cover resists stains and mildew, and protects the finish of your engine-driven welder. Includes heavy-duty grommets for highway travel tie-downs. Fits welder with or without running gear and handle installed.

*Note: Protective cover fits current Champion Elite 225 500580. Use cover 770748 for previous model 500562.*

### No. 2 Stick Cable Set, 50 ft. 195195

Consists of 50-foot (15 m) No. 2 electrode cable with holder, and 50-foot (15 m) work cable with clamp. 200 A, 100% duty cycle.

### Spark Arrestor 300924 Field

Mandatory when operating on California grasslands, brush, or forest-covered land, and all national forests. For other areas, check your state and local laws.

### Full KVA Plug Kit 119172 Field

240 V, 50 A plug (NEMA 14-50P) to fit full KVA receptacle.

**The following accessories are available through Miller/Hobart Service Distributors.**

### Tune-Up and Filter Kit 293399 Field

Includes air, fuel and oil filters, and two spark plugs.

*Note: See Owner's Manual for additional details on maintenance accessories and schedules.*

## Typical Installation

